

When we are looking protecting an installation against over voltage, we have to give some consideration to external cables entering the building. PV installations will come in to this bracket. SPD's for PV systems are to protect the inverter and the fixed installation, therefore PV SPD's should be installed on the DC side of the PV system, before the inverter. These will always be Type 2 devices, unless the building has an external lightning protection system and the correct separation distance to BSEN 62305-3 has not been maintained, where you would install a Type 1 SPD.



Part No. SPD PV600
600V DC



Part No. SPD PV1000
1000V DC

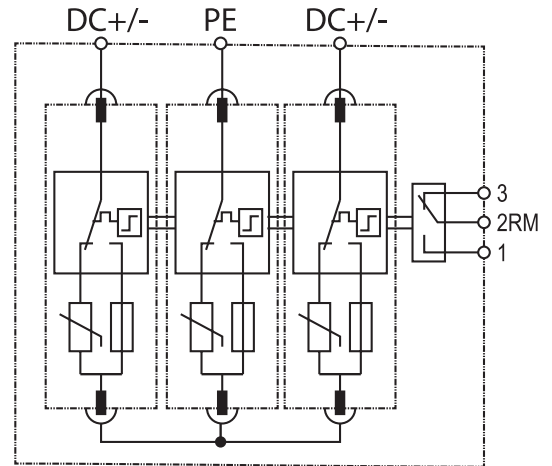

		SPD PV600	SPD PV1000
Classification according to BSEN61643-11		Type 2, Class II	
Maximum PV D.C voltage	U_{cpv}	≤ 600 V DC	≤ 1000 V DC
Maximum continuous operating voltage	U_c	625 V DC	1060 V DC
Short-circuit current rating	I_{scpv}	600A	1000A
Nominal discharge current I_n (8/20 μ s) kA	I_n	20kA	
Maximum discharge current I_n (8/20 μ s) kA	I_{max}	40kA	
Voltage protection level at I_n	U_p	≤ 2.5 kV	≤ 4.0 kV
Voltage protection level at 5kA	U_p	≤ 2.0 kV	≤ 3.5 kV
Response time ns	t_A	<25 ns	
Three way visual indication of status		Green - OK Red - Replace	
Tightening torque		4Nm	
Operating temperature		-40°C to $+80^\circ\text{C}$	
Mounting on		35mm DIN rail	
Dimensions		W 54 x H 90 x D 66mm	
Terminal capacity	Phase line Neutral line	2.5~35mm ²	
	Earth line	4.0~35mm ²	
	Signal line	1mm ²	